



*Original Article*

## Performance and cost analysis of all-optical switching: OBS and OCS

Ekularn Dhavarudha<sup>1,\*</sup>, Chalie Charoenlarnopparut<sup>1</sup>, and Suwan Runggeratigul<sup>2</sup>

<sup>1</sup> *School of Information Computer and Communication Technology,  
Sirindhorn International Institute of Technology, Thammasat University, Rangsit Campus, Pathum Thani, 12121 Thailand.*

<sup>2</sup> *Air Products Industry Co., Ltd.,  
84/8 Mu14 Petchakasem Rd., Nongkaem, Bangkok, 10160 Thailand.*

Received 24 November 2010; Accepted 4 August 2011

---

### Abstract

This paper presents a study of performance and cost analysis of optical circuit switching (OCS) and optical burst switching (OBS) by proposing the clear images of their node architectures and cost formulations. Then, we apply service level agreement (SLA) of the high quality of service application in the terms of network blocking probability and average network delay to demonstrate OCS and OBS performances, their investment costs, and network dimensioning methodology. Applying SLA to our studies can illustrate the impact of contention resolution and blocking resolution schemes to the performances and costs of OBS and OCS, accordingly. The simulations illustrate that OBS applying WC gives the best performance among all architectures deploying the same offered bandwidth. The investigations also show that WC is a major technique contributing high performance gain to both OCS and OBS. Especially for OBS, WC is an important scheme allowing OBS high data grooming property as its performance gain contributing to OBS is much higher than those of OCS. For the cost analysis, OCS is the most economic among all architectures. BA provides the most cost effectiveness among all OBS contention resolution schemes. Lastly, FDL is the least cost effective scheme as it gives little performance enhancement but adds more cost to the network.

**Keywords:** optical burst switching, optical circuit switching, contention resolution, blocking resolution, service level agreement

---

### 1. Introduction

In foreseeable future, all-optical switching is a promising technology that is expected to replace optical-electrical-optical (OEO) switching in wavelength division multiplexing (WDM) networks, because it can overcome some disadvantages of OEO networks. For illustration, OEO components require OEO conversion, which relates to high power consumption and causes high costs for the network. OEO networks are also difficult to be upgraded because they depend on data rates and protocols. Upgrading the system

requires extra equipment or it may need entire system replacement. In contrast, all-optical switching does not require OEO conversion. As it works in all-optical domain with protocol transparent operation, it can offer tremendous bandwidths. All mentioned advantages are key properties for the next generation backbone networks; hence, intensive research works in all-optical switching and components are conducted.

Currently, optical circuit switching (OCS) and optical burst switching (OBS) are the two all-optical switching states of art which are the real candidates for the next generation networks (Anand *et al.*, 2008). OCS is a circuit-switch technology. By its nature, it provides dedicated data channel for each pair of traffic, which is similar to time-division multiplexing. They will not release the occupied channel until the

---

\* Corresponding author.

Email address: [ekularn.d@egat.co.th](mailto:ekularn.d@egat.co.th)

existing call setup is released. This characteristic affects coarse bandwidth granularity. In contrast to OCS, OBS allows data aggregation at every edge node, which permits multiple traffic streams sharing network bandwidths. This property gives OBS high data grooming quality. However, some OBS reservation protocols, such as just enough time (JET) (Yoo and Qiao, 1997), is one way signaling scheme, which may not give reliable wavelength reservation as OCS (Kamiyama, 2004). Both OCS and OBS have their own advantages and drawbacks. They also have different components and architectures, which reflect distinguished investment costs. By this reason, the study of their performance and cost analysis is a very important issue because the final choice to commercialize the next generation switching will be driven by these two factors.

There are research works based on OBS and OCS considering the performance and cost analysis. The researches presented by Kamiyama, (2004), Coutelen *et al.* (2005), and Xue and Yoo, (2005) illustrate the quantitative investigation of OCS and OBS performances and the effects of contention resolution and blocking resolution schemes. However, they do not analyze the OCS and OBS costs. The cost and performance investigation of OBS and OCS are presented by Xiong *et al.* (2000) and Bragg *et al.* (2004), but those studies do not show the influence of OBS contention resolution and OCS blocking resolution schemes related to their costs and performances. In the study of Parthiban *et al.* (2009), the analytical models to compare the costs and blocking probabilities between OCS and OBS networks are illustrated. They show the comparisons of some OBS blocking resolution and OCS contention resolution schemes. However, their work does not present the performance and cost analysis of OBS applying fiber delay line (FDL), burst aggregation (BA), and scheduling and reservation schemes, which are important techniques for resolving contention in OBS. Also, this presentation lacks of performance analysis regarding the delay aspects for both OBS and OCS networks.

From previous works, there are challenges to our further studies in both performance and cost of these two all-optical networks. In this paper, we propose five objectives. First, OBS and OCS node architectures are analyzed. We illustrate their detailed components in four physical switching architectures. Second, node and network cost formulations derived from their architectures are proposed in order to analyze their investment costs. Third, the simulation experiments are conducted to show OBS and OCS performances. Fourth, we apply service level agreements (SLA) to our OBS and OCS simulation models to compare the cost effectiveness of all architectures at the fixed and desirable average network blocking probability and average network delay according to our defined SLA. Last, the studies of contention resolution and blocking resolution schemes, which give an impact on OBS and OCS performances and their network costs, are conducted. In this last objective, the studies include the effects of WC, BA, FDL, and scheduling and reservation algorithms.

This paper is organized into five sections. The proposed switching node architectures with the analysis of their cost models are presented in Section 2. Section 3 presents network models, and Section 4 shows the experimental results. Finally, we conclude our contribution in Section 5.

## 2. Node Architectures and Cost Models

The four types of OCS and OBS switching node architectures are presented in this section followed by the proposed analysis of their cost models. Typically, OCS and OBS consist of three common basic elements (Bragg *et al.*, 2004; Ezouganeli *et al.*, 2005; Parthiban *et al.*, 2009). The first one is an optical cross-connect (OXC) performing as an optical switch. This element is very important because it allows light path connections between two network nodes. A multiplexer/demultiplexer (MUX/DEMUX) is the second element, where MUX plays the role of combining multiple wavelengths ( $\lambda_i$ ) to an output fiber port. DMUX performs wavelength demultiplexing by decomposing wavelengths from input port to be individual signal. A transceiver unit is the third common element. This unit performs wavelength add/drop function in both OCS and OBS cases and also provides one more curtail function as burst aggregating/disaggregating in OBS edge node. If WC is applied to both OCS and OBS, this additional common element is required to perform wavelength conversion. OBS also consists of additional components. The first one is a control unit. It performs as a central processor to control switching and transceiver parts by controlling switching operation and performing operation, administration and maintenance (OA&M) functions. Another element is the FDL unit. This part offers optical buffering for resolving OBS contention. Basically, there are two different node structures, edge node and core node. However, in our model all nodes are assumed to perform both functions. The four physical node architectures and their node cost formulations together with a network cost formulation are analyzed in the following paragraphs.

1) *OCS without WC and OBS without WC*: Node architectures of OCS without WC and OBS without WC are illustrated in Figure 1. Their common elements are OXC, MUX/DEMUX, and a transceiver unit. OXC is a non-external blocking optical switch adopted from Qin and Yang (2002) and Yang and Wang (2005), whereas MUX/DEMUX is adopted from Kakehashi *et al.* (2008). Both OXC and MUX/DEMUX are designed to be implemented with the lowest cross-point among other schemes, which are suitable only for the communication requiring the same wavelength assignment for all hops along one path. Unlike OCS, OBS has two extra components, which are a control unit and a FDL unit. We adopted FDL architecture from Xiong *et al.* (2000) and Yoo and Qiao (2000). This model requires splitter/combiner performing signal splitting and combining to the FDL channels. MUX/DEMUX is also needed to multiplex/demultiplex the contending signals to FDL channels. Last, fiber

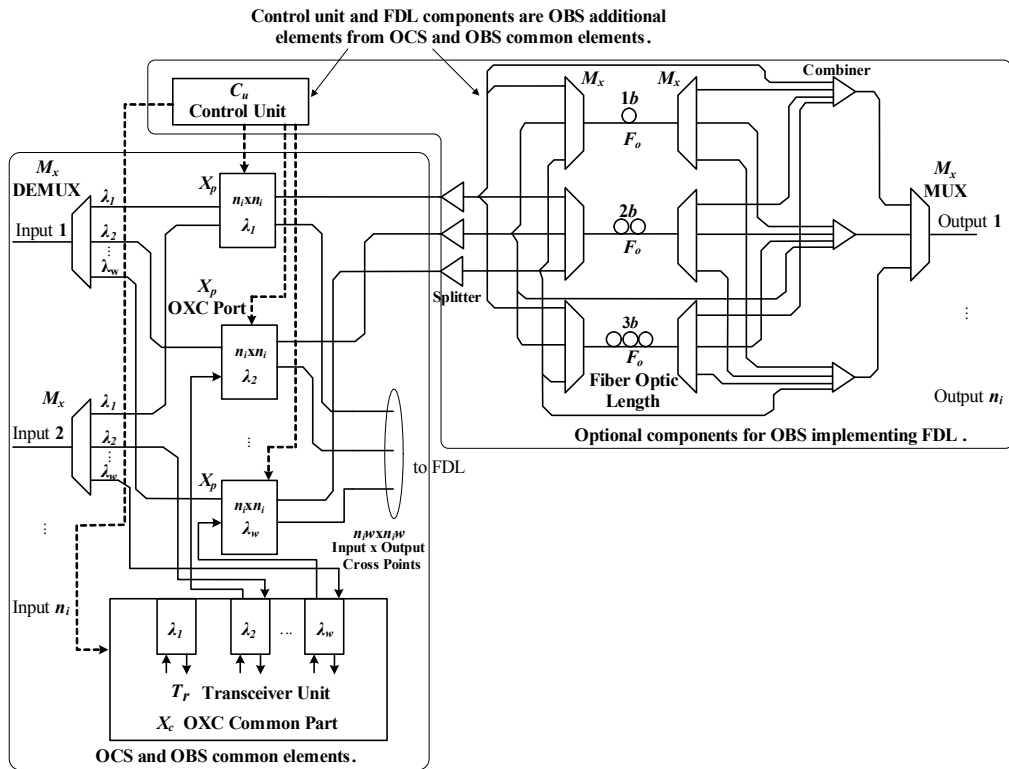

Figure 1. Node architectures of OCS without WC and OBS without WC.

optic cables operating as an optical buffer to temporarily delay the contending bursts before sending them to available channels is required in FDL component. From analyzing these architectures, we propose OCS without WC node cost ( $C_{Ci}$ ) presented in Equation 1 and OBS without WC node cost ( $C_{ji}$ ) illustrated in Equation 2. Their details are explained as follows.

$C_{Ci}$  is the summation of the three component costs, including OXC component cost, MUX/DEMUX component cost, and transceiver unit component cost. OXC component cost consists of an OXC common part or common chassis equipment unit price ( $X_c$ ) and the costs of total switching port count (Sengupta and Kumar, 2003; Kamiyama, 2004). Let  $n_i$  be the total number of input/output fiber ports for node  $i$ , let  $w$  be the number of wavelengths in one fiber link, and  $X_p$  be the unit price of one OXC port. The cost of total switching port count becomes  $n_i w X_p$  and then OXC component cost becomes  $(X_c + n_i w X_p)$ . MUX/DEMUX component cost is the cost of total amount of MUX and DEMUX used in one switching node. Let MUX/DEMUX unit price be  $M_x$ . Thus, this component cost is equal to  $2n_i M_x$ . Lastly, the transceiver unit component cost is the total cost of transceiver units applied in one switching node. Let  $T_r$  denote a transceiver unit price. Then the transceiver unit component cost is equal to  $w T_r$ .

$$C_{Ci} = (X_c + n_i w X_p) + 2n_i M_x + w T_r \quad (1)$$

For OBS, the additional terms, which are the cost of a control unit ( $C_u$ ) and the optional FDL component cost ( $F_{Di}$ ) are added to Equation (1). Then we obtain OBS without WC cost ( $C_{ji}$ ) as illustrated in Equation (2).

$$C_{ji} = C_u + (X_c + n_i w X_p) + 2n_i M_x + w T_r + F_{Di} \quad (2)$$

$$\text{where } F_{Di} = 2n_i D M_x + \sum_{j=1}^D (j b F_o).$$

When FDL is utilized in the network, the optional FDL component cost ( $F_{Di}$ ), which depends on the maximum number of FDL slots ( $D$ ) and the length of fiber optic cable used for one fixed FDL delay unit ( $b$ ), is included. For illustration, if we design our FDL for  $D=3$ , there will be 4 output ports, which are  $0b$  delay (an original outgoing port),  $1b$  delay,  $2b$  delay, and  $3b$  delay. The first term of  $F_{Di}$  is the cost of the total number of MUX and DEMUX used in the FDL unit, which is equal to  $2n_i D M_x$ . The second term is the cost of the total fiber optic cables (km) used in FDL component of which  $F_o$  denotes unit price per kilometer of fiber optic cable. It is noted that we neglect the cost of splitter/combiner in this analysis because their costs are less significant compared to other components (Ezouganeli *et al.*, 2005).

2. *OCS with WC and OBS with WC*: Figure 2 illustrates OBS with WC and OCS with WC node architectures. Similarly to the first architectures, these two architectures consist of common elements including OXC, MUX/DEMUX, a transceiver unit, and WC. However, OXC is adopted from

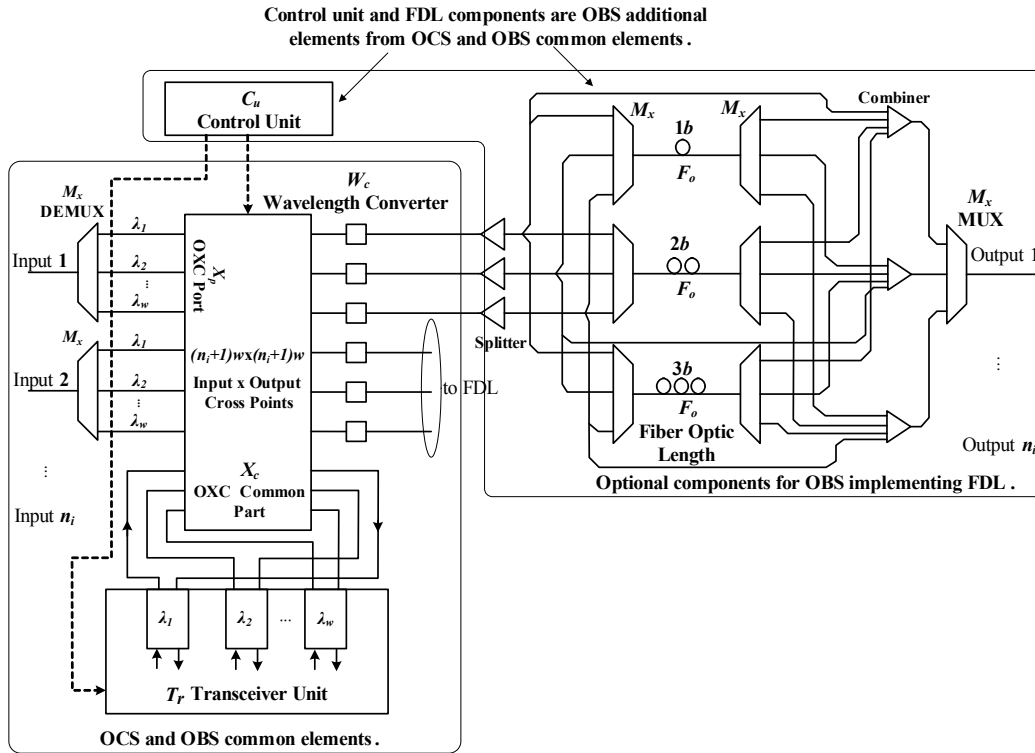

Figure 2. Node architectures of OCS with WC and OBS with WC.

Baldine *et al.* (2003), Yang and Wang (2005), and Kakehashi *et al.* (2008). This model is a conventional wavelength interchangeable optical switch, which includes wavelength converter performing full WC for each output port. It provides a single stage design allowing full cross connection from any wavelength to all other wavelengths and gives the lowest number of the cross-points among other schemes of single stage implementations. The second element is MUX/DEMUX adopted from Kakehashi *et al.* (2008), which is suitable for wavelength multiplexing/demultiplexing with full WC. A transceiver unit is the third element. OBS also requires extra hardware as a control unit and optional FDL component, including splitter/combiner, MUX/DEMUX, and fiber optic cable. This model is adopted from Xiong *et al.* (2000) and Yoo and Qiao (2000) as well.

Node costs of OCS with WC ( $C_{Cwi}$ ) is presented in Equation 3 and the terms of MUX/DEMUX component cost and transceiver unit component cost are derived in the same way as  $C_{Ci}$ . OXC in this model can allow wavelength cross-connection at the transceiver unit with the number of  $w$  wavelengths; therefore, the total switching port count increases and the term of OXC component cost becomes  $(X_c + (n_i + 1)wX_p)$ . Last, the cost of WC component is equal to  $n_i wW_c$  (the cost of total WC applied in one node) where  $W_c$  is a unit price of WC.

$$C_{Cwi} = (X_c + (n_i + 1)wX_p) + 2n_i M_x + wT_r + n_i wW_c \quad (3)$$

Node cost of OBS with WC ( $C_{Bi}$ ) in terms of control unit cost, MUX/DEMUX component cost, transceiver unit component cost, and FDL component cost are same as in the  $C_{Ci}$  case. In terms of costs for OXC component and WC component can also be analyzed similarly to their costs in  $C_{Cwi}$  since their architectures are alike. Thus,  $C_{Bi}$  is illustrated in Equation 4.

$$C_{Bi} = C_u + (X_c + (n_i + 1)wX_p) + 2n_i M_x + wT_r + n_i wW_c + F_{Di} \quad (4)$$

$$\text{and } F_{Di} = 2n_i D M_x + \sum_{j=1}^D (j b F_o)$$

Considering the analysis of total network cost, let  $N_i$  be the number of nodes which have  $n_i$  input/output fiber ports, and let  $M$  be the total number of input/output fiber ports for node  $i$ , which has maximum ports in the network. The total network cost ( $C_T$ ) presented in Equation 5 includes the summation of node costs ( $C_i$ ), the cost of total optical link used in the network ( $LF_o$ ), and the total optical amplifier cost ( $n_a A_o$ ). The node cost  $C_i$  depends on each node architecture *i.e.*  $C_i \in \{C_{Ci}, C_{Ci}, C_{Cwi}, C_{Bi}\}$ , and  $L$  is the total length of fiber optic links used in the network (km). The variable  $n_a$  and  $A_o$  denote the total number of optical amplifiers applied in the network and an optical amplifier unit price, respectively.

$$C_T = \sum_{i=1}^M \sum_{j=1}^{N_i} (C_i) + LF_o + n_a A_o \quad (5)$$

The proposed equations are very useful for future works because they can demonstrate node and network costs despite the alteration of market pricing. The unit price for each component part and their corresponding variables including parameters and their descriptions for Equation 1 to 5 are detailed in Table 1. It is noted that our cost parameters and the cost formulations represent the first order of capital expenditure cost (CAPEX), which excludes operating expenditure cost (OPEX) and non-hardware costs. By substituting each unit price from Table 1 into Equation 1 to 5, we are able to determine the numeric cost for each model and understand the cost and performance trade-off among various models of OCS and OBS towards our further discussion in the experimental results.

### 3. Network Models

Our backbone network is a 14-node and 21-link NSFNET (Ramaswami and Sivarajan, 1996). Figure 3 illustrates the topology and its corresponding link propagation delays (s). The traffic for each node-pair  $t_{ij}$  (the traffic demand between node  $i$  and node  $j$ ) is generated by allocating a random amount chosen from a uniform distribution (Ramaswami and Sivarajan, 1996). Every population from this distribution is scaled up in order to give the maximum traffic pair of 400 Gbps. This traffic model is generated by Poisson process with arrival rates of  $kt_{ij}/X$ .  $X$  is an average burst

length duration which is followed exponential distribution, and we assign this value to 8 Mb (Kamiyama, 2004).  $k$  denotes the traffic demand coefficient applied to each simulation in order to study its result upon varied traffic load. All simulations are experimental based which varying  $k$  from 0 to 1 with a step of 0.1.

#### 3.1 OCS Models

Our OCS network is a static wavelength routed network with offline routing algorithm (Dixit, 2003), which is one of the most practical and applicable all-optical circuit-switched networks. According to its static wavelength reservation property, OCS network requires pre-wiring to the cross-connect switches and it requires routing and wavelength assignment (RWA). Implementing RWA also contributes to the reduction of network blocking probability. Besides RWA, the most important OCS blocking resolution technique is WC, because WC can eliminate wavelength continuity constraints. However, BA and FDL are not such techniques for OCS due to impractical implementation for OCS (Dixit, 2003; Chen *et al.*, 2004). Thus, in this paper we study only OCS implementing WC and OCS without WC architectures. We apply RWA to both architectures in order to determine efficient and sufficient bandwidth for carrying our traffic demands. The following procedure is the methodology for our RWA scheme adopted from Schupke and

Table 1. Parameter definition and unit price for part variables.

Parameter	Definition	Part / Variable	Part Unit Price(\$USD)
$n_i$	The total number of input/output fiber ports for node $i$ .	MUX/DEMUX / $M_x$	200,000 (Kamiyama, 2004)
$N_i$	The number of nodes which have $n_i$ input/output fiber ports.	OXC Common Part / $X_c$	500,000 (Sengupta and Kumar, 2003)
$M$	The total number of input/output fiber ports for node $i$ , which have maximum ports in the network.	OXC Port / $X_p$	41,000 (Sengupta and Kumar, 2003)
$L$	The total length of fiber optic links used in the network (km).	Transceiver / $T_r$	80,000 (Kamiyama, 2004; Gunkel <i>et al.</i> , 2006)
$w$	The number of deployed wavelengths in fiber link.	Wavelength Converter / $W_c$	5,000 (Ezouganeli <i>et al.</i> , 2005)
$D$	The maximum number of applied FDL slots.	OBS Control Unit / $C_u$	40,000 (Xiong <i>et al.</i> , 2000; Baldine <i>et al.</i> , 2003)
$b$	The length of fiber optic cable used for one fixed delay unit (km).	Optical Amplifier / $A_o$	240,000 (Kamiyama, 2004; Gunkel <i>et al.</i> , 2006)
$n_a$	The total number of optical amplifiers implemented in the network (assuming an optical span of 500 km)(Simons, 2006).	Fiber Optic Cable (per km). Assuming one cable is able to contain maximum of 250 wavelengths (Parthiban <i>et al.</i> , 2009) / $F_o$	3,000 (Parthiban <i>et al.</i> , 2009)

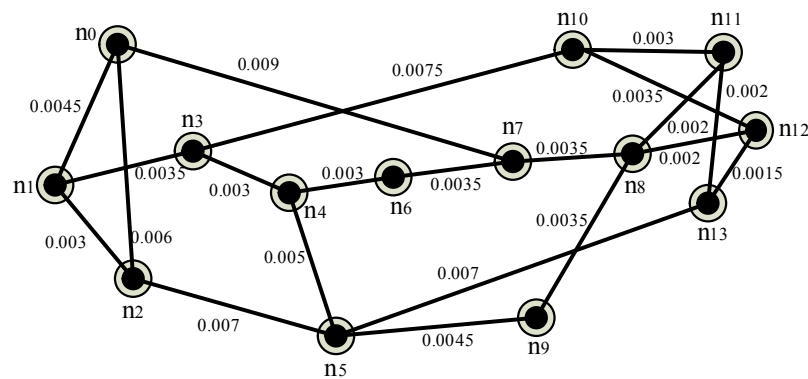

Figure 3. 14-node and 21-link NSFNET network and link propagation delays.

Sellier (2001). The result of this scheme is an optimum solution giving an optimum number of deployed wavelengths per each optical fiber link. The procedure of our RWA is detailed as follows:

1) *Wavelength calculation*: Calculating the number of wavelengths ( $P_{wij}$ ) assigned to each traffic  $t_{ij}$  by  $P_{wij} = \lceil t_{ij} / C_w \rceil$ ,  $C_w$  denotes wavelength capacity, which is set to 10 Gbps.

2) *Wavelength minimization*: Minimizing the number of switching ports and the number of wavelengths deployed in each node by mapping the required  $P_{wij}$  of each  $t_{ij}$  with its logical routing to the physical topology.

3) *Fiber path minimization*: Assigning shortest path algorithm with minimum hop count for our logical routing in order to keep fiber usage and light path length low.

4) *Wavelength assignment*: Applying DSATUR graph coloring technique (Brelaz, 1979) with the first fit wavelength assignment (Dixit, 2003) to each fiber path in order to find the optimum number of wavelengths per each optical fiber link.

Based on the above described procedure, this technique gives 98 wavelengths per one unidirectional optical fiber cable for our network model.

### 3.2 OBS Models

We set the OBS processing time to 80  $\mu$ s (Kamiyama, 2004). The switching configuration time is 10  $\mu$ s (Choi *et al.*, 2005). The offset time is the summation time between the configuration time and total processing time of all nodes along the setup path for each connection (Choi *et al.*, 2005).

In order to reduce OBS contention and enhance its performance, there are several techniques that can be applied, generally called contention resolutions. We can categorize OBS contention resolution in three domains (Chen *et al.*, 2004), which are a time domain, a wavelength domain, and a link domain. BA and FDL are time domain resolutions. BA takes place in electronic buffer of OBS ingress node. The buffer holds a number of incoming packets and assembles them to be a burst. There are several techniques for BA. For instance, burst length duration criteria; one burst is crated

from several assembled packets after the burst length meets criteria. Another BA technique is the time duration criteria, where one burst is crated from several assembled packets within certain time thresholds. BA is an important technique because it is a mechanism for OBS to smooth input traffic. Therefore, burst and contention in the network are alleviated and link utilization is consequently improved (Du and Sbe, 2007). FDL is a fiber optic cable acting as a light buffer in time domain. It allows contending bursts traveling along optical fiber lines for temporary delay before sending them to available channels.

Scheduling and reservation scheme and WC are contention resolution mechanisms in wavelength domain. The first technique is wavelength scheduling, which is an effective mechanism to manage bandwidth occupation for OBS. WC is very important to OBS because it resolves wavelength continuity constraint and allows a high data grooming property. In link domain, the technique of deflection routing (DR) can be used for contention resolution. Deflection route is selected in this scheme when there are contentions at the contending node. The contending bursts are routed to an alternative path in order to avoid the main congested path.

In this study, we apply JET protocol and the first fit wavelength assignment for both OBS without WC and OBS with WC. For OBS with WC experiments, the two effective channel scheduling algorithms based on JET protocol, the latest available unscheduled channel (LAUC) (Xiong *et al.*, 2000) and the latest available unscheduled channel with void filling (LAUC-VF) (Xiong *et al.*, 2000), are implemented as they require full wavelength conversion. The basic idea of LAUC-VF is minimizing voids between the two consecutive data bursts by scheduling the latest available unused data channel. This algorithm affects the minimization of a gap between the arriving burst and the previous one and it is very effective in the sense of giving high channel utilization. Quite similar to LAUC-VF is LAUC, which reserves a wavelength by scheduling the latest available unused data channel. However, it does not minimize the void between two consecutive bursts. This scheduling is suitable for high speed

environment because its algorithm is not as complex as the one in LAUC-VF. In this paper, we illustrate and compare the performances of both algorithms.

Beside the scheduling schemes, we apply BA and FDL techniques to our experiments based on OBS. Note, DR is not included in our study because this scheme has a tendency to increase the network blocking and may also introduce network instability if deflection routing and loop avoidance algorithms are not well designed (Dixit, 2003). The study by Gauger *et al.* (2004) shows that DR introduces more blocking in the network, because it increases the number of deflected hops.

Our BA is set by burst size threshold using burst length duration because it can ensure traffic smoothness, which yields effectively reducing network blocking probability. This scheme may introduce additional uncontrolled delay to the network when carrying light load traffics, but we control the maximum delay in all experiments by controlling a target end-to-end delay below our offered boundary. The burst size threshold is set to the average burst length duration ( $B$ ) in bytes. We implement the variation of BA with multiple of  $B$  *e.g.*  $1B$ ,  $2B$ , etc.  $B$  is set to 1,000,000 bytes (Kamiyama, 2004). This value is quite high compared to the switching configuration time; therefore, the link utilization of the network is not degraded (Choi *et al.*, 2005).

One fixed delay unit  $b$  of FDL is set to the average burst duration. In time domain, this value is equivalent to 0.8 ms and it requires 160 km of optical fiber cable. We conduct experiments based on the varied numbers of FDL slots  $D$  from one to three units. The maximum distance of fiber optic cable for  $3D$  units is equivalent to 480 km. We assume the maximum span of fiber optic cable is 500 km (Simons, 2006). In this case, a  $3D$  unit FDL does not require fiber optic cable longer than this maximum span. Hence, our FDL model does not need an optical amplifier for the FDL cable.

## 4. Experimental Results

### 4.1 Service level agreement

SLA is a key component of service level where service providers specify their performance agreement to end users. Service provider may offer some agreement such as minimum network delay and packet loss to the customer. We offer a gold class of service SLA to our networks by giving average network blocking probability (in the sense of packet blocking probability) less than 0.03. Our networks can carry such a high quality of service for the real time application as voice over Internet Protocol (VoIP) (Gauger *et al.*, 2004). We also offer maximum average network end-to-end delay for our SLA to 50 ms. This value can efficiently carry VoIP application because the standardization recommends one way network end-to-end delay tolerance for VoIP of 150 ms (James *et al.*, 2004; Tachibana and Kasahara, 2006). In our design, the networks are prepared for delay time compensation, which can tolerate some extra network delays such as pro-

cessing delay, queuing delay, packetization delay, codec delay, caused by electronic devices at edge nodes.

In practical, the first consideration in implementing a new backbone network is to specify the performance requirement for the network. Then, the process of reducing investment costs by maintaining desirable performances shall be considered for the next step. We demonstrate the same concept as practical network designing by conducting various experimentations based on OBS and OCS basic architectures. The performances of these networks shall give such a satisfied SLA as mentioned earlier and the costs of all architectures are analyzed to give the prospect of their performance and cost trade-off. Next, we conduct more studies in OBS applying contention resolution schemes and OCS applying blocking resolution techniques by giving them the same offered SLA. From these experiments, we expect to reduce wavelength requirements from the standard OBS and OCS, which implies investment cost reduction. Thus, the analysis for cost effectiveness of each OBS contention resolution scheme and OCS blocking resolution technique is possible.

### 4.2 Simulation results

All our experiments are simulated based on ns2 Simulator (DAWN Networking Research Labs, 2002) and they are conducted according to the desirable SLA as explained in Section 4.1 with various network models as listed in Table 2. Among all models, some of them have common physical node architecture such as OBSL and OBSLV, both of which share the same node architecture consisting of only software elements differently implemented in a processor of a control unit. A node applying BA such as OBSLB also requires no extra hardware from OBSL. Since BA is processed in an electronic buffer in OBS transceiver unit, their physical architectures are similar to the original physical architectures. Therefore, node costs of the mentioned models can be obtained from Equation 4.

From the RWA problem based on OCS networks, which is explained in Section 3.1, the optimum solution gives 98 wavelengths for our network dimensioning. In contrast to OCS, since OBS is able to reserve channel and setup routing in dynamic fashion, the contribution of RWA for OBS is trivial (Dixit, 2003). However, to study the performances of basic models based on the same criteria, we applied the first simulation based on the same network resource by deploying 98 wavelengths to OBSLV, OBSL, OBSJ, OCS, and OCSW networks. As illustrated in Figure 4, OBSLV shows the best performance by providing the lowest blocking probability, while OBSL is the second best and OCSW and OCS are the third and fourth, respectively. OBSJ is outperformed by others.

Observing the first simulation no model satisfies SLA. Further experimentations are then repeated for our observed networks until the networks give their SLA satisfaction and the number of wavelength usage for each model is able to be

Table 2. Simulation models and their physical node architectures.

Simulation Model	Applied Technique	Physical Architecture
OBSLV	JET LAUC-VF	OBS with WC
OBSLVB	JET LAUC-VF with BA	OBS with WC
OBSLVF	JET LAUC-VF with FDL	OBS with WC
OBSLVBF	JET LAUC-VF with BA and FDL	OBS with WC
OBSL	JET LAUC	OBS with WC
OBSLB	JET LAUC with BA	OBS with WC
OBSLF	JET LAUC with FDL	OBS with WC
OBSLBF	JET LAUC with BA and FDL.	OBS with WC
OBSJ	JET	OBS without WC
OBSJB	JET with BA	OBS without WC
OBSJF	JET with FDL	OBS without WC
OBSJBF	JET with BA and FDL	OBS without WC
OCSW	OCS applying WC	OCS with WC
OCS	OCS	OCS without WC

identified.

Various experiments based on OBS applying LAUC-VF scheduling (OBSLV, OBSLVB, OBSLVF, and OBSLVBF) are illustrated in Figure 5. From the repeated simulations, OBSLV can achieve network blocking probability of 0.03 by deploying 101 wavelengths. Then, we simulate the experiments based on OBSLVB. The results show an increasing BA to the maximum size of  $48B$ , so that the network achieves blocking probability and average network end-to-end delay in the boundary we set. With this scheme, we can also reduce the number of the deployed wavelengths from 101 to 97 wavelengths. If we implement BA longer than  $48B$ , the blocking probability can be further reduced below 0.03, but the delay of setting the BA thresholds beyond  $48B$  is more than the limitation of 50 ms. Consequently,  $48B$ -BA is the maximum threshold for the OBSLVB model. Next, we studied more about the OBS implementing FDL as OBSLVF model. Applying OBSLVF for the maximum  $3D$  units, it still requires 101 wavelengths that is same as the original OBSLV, which gives blocking probability in the boundary of 0.03. This result implies that the FDL contribute very little performance enhancement. We also try to elaborate this simulation by applying  $2B$ -BA in OBSLVB. The result shows that this model operates at 100 wavelengths for achieving our SLA. Combining BA and FDL for  $2B$ -BA and  $3D$ -FDL in OBSLVBF, there is no significant improvement compared to  $2B$ -BA of OBSLVB due to their requirement of the same amount of wavelengths (100 wavelengths). By comparing those results, we can conclude that BA gives much more performance gain to the OBS networks than the FDL. As burst traffics require very high bandwidth consumption for a short period of time, BA can resolve this problem by smoothing traffic at ingress sites to alleviate bandwidth requirement within that short period of time. Although, FDL and BA introduce more delays to the network, the delays from all experiments are still within our boundary as can be observed from Table 3.

We also conduct experiments based on OBSL comparable to the OBSLV experiments. The results of OBSL are

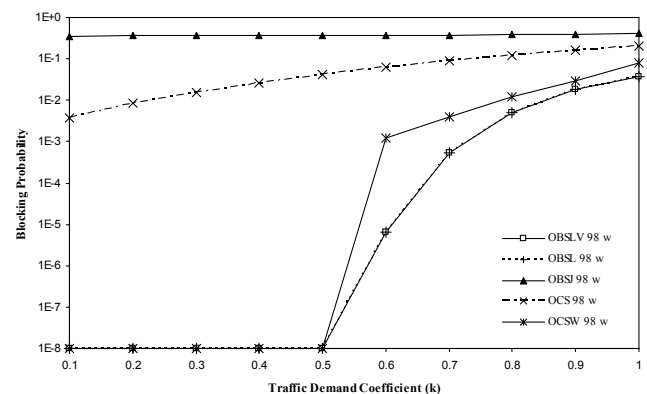

Figure 4. Blocking probabilities of OBSLV, OBSL, OBSJ, OCS, and OCSW.

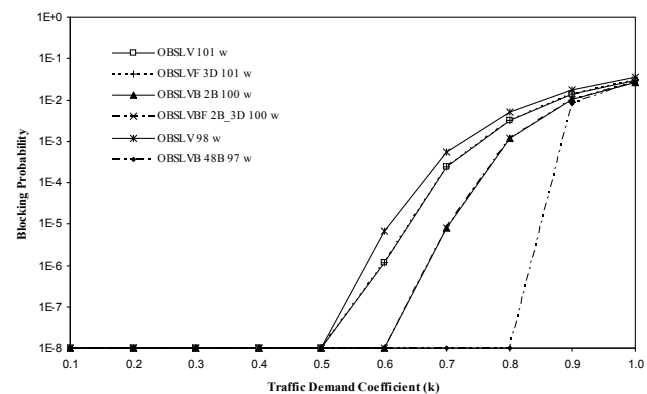

Figure 5. Blocking probabilities of OBSLV, OBSLVB, OBSLVF, and OBSLVBF.



Table 3. Cost and performance analysis

Simulation Model	Node Cost (\$MUSD)			Network Cost (\$MUSD)	Blocking x 10 <sup>-3</sup> For $k=1$	Delay (ms) For $k=1$
	$n_i=2$	$n_i=3$	$n_i=4$			
OBSLVB $w=97$ ( $B=48$ )	22.0	26.9	31.7	439.1	28.3	49.6
OBSLVB $w=100$ ( $B=2$ )	22.6	27.6	32.6	450.0	26.5	12.8
OBSLVF $w=101$ ( $D=3$ )	28.1	34.4	40.6	544.4	29.6	12.2
OBSLVBF $w=100$ ( $B=2, D=3$ )	27.9	34.1	40.3	540.7	26.3	12.8
OBSLV $w=101$	22.9	27.9	32.9	453.6	29.7	12.0
OBSLB $w=97$ ( $B=48$ )	22.0	26.9	31.7	439.1	28.3	49.6
OBSLB $w=100$ ( $B=2$ )	22.6	27.6	32.6	450.0	26.6	12.8
OBSLF $w=101$ ( $D=3$ )	28.1	34.4	40.6	544.4	29.7	12.2
OBSLBF $w=100$ ( $B=2, D=3$ )	27.9	34.1	40.3	540.7	26.4	12.8
OBSL $w=101$	22.9	27.9	32.9	453.6	30.0	12.0
OBSJ $w=250$	41.8	52.5	63.1	797.9	380.7	11.5
OBSJB $w=250$ ( $B=50$ )	41.8	52.5	63.1	797.9	379.6	49.6
OBSJF $w=250$ ( $D=3$ )	45.5	58.0	70.5	875.2	379.2	11.7
OBSJBF $w=250$ ( $B=46, D=3$ )	45.5	58.0	70.5	875.2	373.1	49.3
OCSW $w=106$	23.9	29.2	34.4	471.2	28.4	9.6
OCS $w=122$	21.1	26.5	31.9	433.6	27.9	9.3

very similar to OBSLV and they contribute the same performance tendencies upon various load capacities similar to the cases of OBSLV. Hence, all OBSL graphical results are not presented in this section but all performances of OBSL simulated at  $k=1$  are illustrated in Table 3. The experimental results show LAUC gives less efficiency than LAUC-VF because they give higher blocking probabilities than OBSLV in all comparable experiments. But they still require the same amount of wavelengths as OBSLV to achieve our required SLA. Observing from Figure 4, OBSJ operating at 98 wavelengths has a network blocking probability that is higher than 0.03. To reduce its blocking probability, we then repeat the simulation by increasing the number of wavelengths. The result in Figure 6 shows that the OBSJ applying 250 wavelengths contributes to a network blocking probability at  $k=1$ , which is above our SLA requirement. OBSJ network offers high blocking probability because there is no WC presented in this model. Without implementing WC at intermediate hops, the burst streams have to traverse within the same wavelength selected at an edge node. In addition, OBSJ unfortunately does not reserve a dedicated channel along one communication path as same as OCS does. Therefore, at every intermediate node it has to search again for that same available channel. As far as the burst streams traversing in the network and passing more intermediate hops, they have more tendencies to be blocked because they are required to reserve the original wavelength as selected at their source node. As the number of the deployed wavelengths is beyond the limitation, we do not further conduct the experiment on OBSJ with more than 250 wavelengths.

Next, we consider the implementation of BA and FDL in OBSJ with 250 wavelengths (OBSJB, OBSJF, and OBSJBF)

in order to observe OBSJ performance enhancement as presented in Figure 6. The simulation of OBSJB shows that BA can alleviate the blocking probability. 50B is the maximum burst size that gives OBSJB average network delay in limitation but its blocking probability still not satisfies the SLA. For OBSJF implementing maximum delay slots of 3D, its performance outperforms OBSJB implementing 50B-BA. If we compare their performances to the original OBSJ, FDL is able to enhance OBSJ performance in both high and low load capacities. In contrast, BA achieves an enhancement at high load capacities ( $k$  is more than 0.5), while at low load capacities BA causes more contention than the original OBSJ. This is because at low load capacities dropping large burst frame sizes comparable to its traffic capacity causing

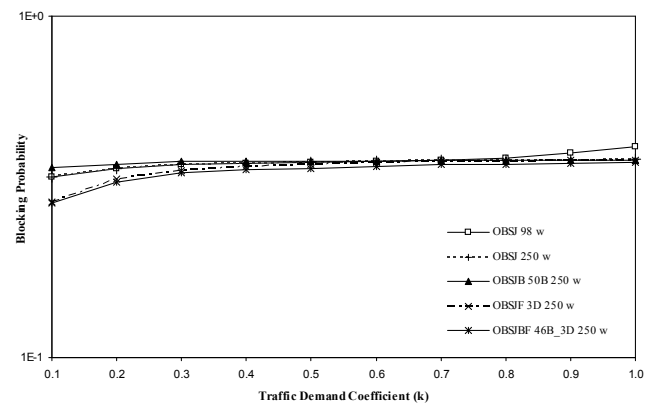

Figure 6. Blocking probabilities of OBSJ, OBSJB, OBSJF, and OBSJBF.

more blocking probability to the network. The combination of implementation both 46B-BA and 3D-FDL for OBSJBF presents the best performance among all OBSJ architectures deploying 250 wavelengths. The main contribution comes from FDL. Obviously, as we know that implementing larger burst size of BA and utilizing more  $D$  slots introduces more delays to the network but implementing 46B-BA and 3D-FDL can still make OBSJBF satisfy the delay boundary. However, as mentioned before none of them is able to give a blocking probability according to our SLA.

The performances of OCS and OCSW are evaluated by repeating RWA procedures to both networks. In this evaluation, we repeat the experiments until every traffic pair achieves a blocking probability of 0.03. From the repeated simulations, OCS requires 122 wavelengths and OCSW needs 106 wavelengths to satisfy the given constrains. Figure 7 illustrates the performances of OCS and OCSW using the revised number of wavelengths comparing to the original models deploying 98 wavelengths. The simulations show WC contributes to the enhancement of OCS. As we can see that OCS requires 122 wavelengths, while OCSW requires only 106 wavelengths, which reduces much of the deployed bandwidth. All experiments of OCS and OCSW give average network delays bounded in our SLA.

For delay aspect, Figure 8 shows average network end-to-end delays of the best solutions in previous experiments. These results show that traffic load capacities have very less influence on OBS and OCS average network end-to-end delays because their architectures do not include electrical buffers at intermediate nodes, which are major components producing extra delays to the networks.

After researching the performances of previous experiments, we then analyze their cost and performance trade-off for OBSLV, OBSL, OBSJ, OCS, and OCSW together with their models applying contention resolution techniques. The mentioned experiments are presented at the maximum load capacities ( $k=1$ ) to show their blocking probabilities, average network delays, node costs, and network costs. All results are illustrated in Table 3. Their costs are given in million US Dollar (MUSD) and they are analyzed from Equation 1 to 5 by substituting all variable parameters and unit prices given in Table 1. For illustration, focusing on the study of OBSLVF implemented with  $w=100$  and  $D=3$ , Equation 4 is used to calculate node costs and it gives node costs  $n_2$ ,  $n_3$ , and  $n_4$  of 28.1, 34.4, and 40.6 MUSD respectively. In our network model, node  $i$  consists of the maximum input/output ports of 4 ports then  $M=4$  and the network cost can be calculated from Equation 5, which is equal to 544.4 MUSD.

Observing from Table 3 and comparing the performances of OBS with WC operating at 101 wavelengths, OBSLV outperforms OBSL approximately 1 percent, but their costs are equal. As they share the same physical architecture, their costs based on the comparable models are equal. This result shows that the LAUC-VF algorithm can enhance OBS performance and makes the OBS more cost effective than LAUC. If we compare the costs of OBSLV operating at

101 wavelengths to the costs of OBSJ deploying 250 wavelengths, the first one is approximately 43 percent cheaper than the second one, but its performance is improved approximately 92 percent. This implies that WC gives major contribution to OBS performance enhancement and affects the cost reduction. From the cost aspect, we can highlight in addition to the performance analysis that although WC gives additional costs to the network; it can improve very high performance to OBS. Therefore WC provides a major contention resolution to the OBS in terms of both network performance and cost effectiveness.

As applying BA to OBS with WC causing wavelength reduction, BA contributes to the cost reduction. To illustrate the advantage of BA, the cost of OBSLVB using 97 wavelengths with 48B-BA is 3.2 percent cheaper than the cost of original OBSLV using 101 wavelengths; which gives comparable blocking probability. In contrast to BA, implementing FDL alone to OBSLVF cannot reduce the number of the deployed wavelengths, but it introduces more costs to the network. Meanwhile, implementing 2B-BA to OBSLVB can give satisfied performances and they reduce one wavelength usage. This model contributes to the cost reduction from the

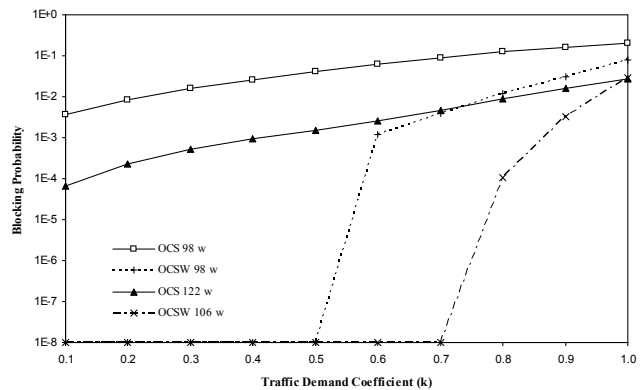

Figure 7. Blocking probabilities of OCS and OCSW.

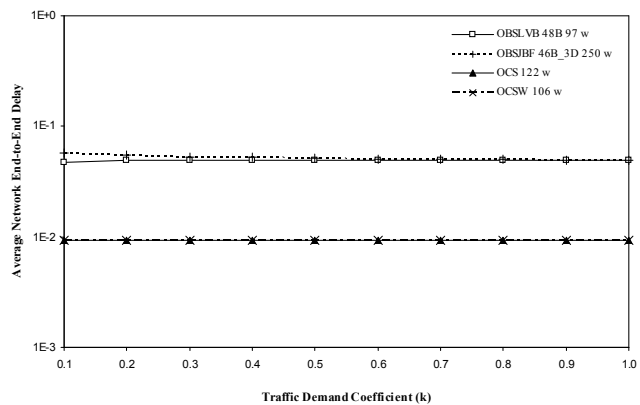

Figure 8. Average network end-to-end delays of OBSLVB, OBSJBF, OCS and OCSW.

original OBSLV by 0.8 percent. Next, the combined implementation of 2B-BA and 3D-FDL to OBSLVBF increases the costs from the original OBSLV by 18.8 percent. Clearly, this combination can reduce one wavelength but its cost is raised from additional cost of FDL component.

OBSJ deploying 250 wavelengths does not meet our SLA in the sense of blocking probability. When we improve the performance of OBSJ by implementing 50B-BA, it can enhance OBSJ performance by 0.29 percent, while the cost does not increase. Implementing 3D-FDL based on OBSJF can enhance the performance by 0.39 percent; however, the cost is increased by 9.68 percent. Lastly, the implementation of 46B and 3D based on OBSJBF can enhance the OBSJ performance approximately by 2 percent whereas FDL components add 9.68 percent more cost to this architecture.

By maintaining our SLA on both OCS and OCSW, OCSW requires 106 wavelengths and OCS needs 122 wavelengths. Comparing their costs, OCSW is approximately 8.8 percent more expensive than OCS. This analysis shows that WC has an impact on the performance enhancement of OCS; however, the contribution of WC in term of cost-effectiveness is less than that of OBS. If we compare the costs of OBS and OCS based on comparable performance, the cost of OBSLV operating at 97 wavelengths is 1.25 percent higher than the cost of OCS operating at 122 wavelengths. In addition, OBSLV is 7.31 percent cheaper than OCSW giving comparable performances. Even though OCS requires great amount of wavelengths to give satisfied SLA, it is still less expensive than OBSLV and OCSW. This analysis implies that the cost of WC has a great impact on the costs of OCS and OBS. Therefore, in the future, if the cost of WC components will decrease because of market mechanism, OBS and OCS implementing WC will be very interesting technologies due to their high performances and scalabilities. Lastly, the cost comparison between OBSLV and OCSW emphasizes implementing WC based on OBS is more cost effective than in case of implementing in OCS technology.

## 5. Conclusion

Our study shows WC is a major technique that contributes higher performance gain to OBS than in the case of OCS. Moreover, BA and FDL can resolve contention for OBS with WC, but BA provides more influence in improving their performances than FDL.

For cost analysis, BA is a cost effective scheme for OBS with WC since if we maintain our SLA, BA can reduce wavelength usage without additional cost. FDL can gradually improve OBS with WC performance; however, it adds more cost to the network. Typically, WC is costly but provides much improvement to both OCS and OBS networks. Especially for OBS, WC is a very important technique that makes OBS a high data grooming solution and enhances its performance to satisfy our SLA.

In practical, there is no absolute solution for network designing. This paper provides a guideline for OBS and OCS

evaluation in term of network costs and performance analysis to networking engineers and investors. We analyze numerical component and network costs, which practically tend to vary upon market forces. These market pricing may be decreased if the switching architecture dominates the telecommunications market due to mass production. Even though, the future network costs for all-optical switching may be altered from our analysis, network engineers and investors can still make use of our proposed guidelines and formulations for their network realizations and investments.

## References

- Anand, K.R., Anshuk, C. and Pradeep, K.B. 2008. OBS for GENNEXT optical networks. Proceedings of 2nd National Conference Challenges & Opportunities in Information Technology, Mandi Gobindgarh, India, March 29, 2008, 189-193.
- Baldine, I., Cassada, M., Bragg, A., Karmous-Edwards, G. and Stevenson, D. 2003. Just-in-time optical burst switching implementation in the ATDnet all-optical networking testbed. Global Telecommunications Conference, San Francisco, United States of America, December 1-5, 2003, 2777-2781.
- Bragg, A., Baldine, I. and Stevenson, D. 2004. A parametric, first order analysis of optical burst switched (OBS) networks. Microelectronic Center of North Carolina (MCNC) Research and Development Institute. Proceedings of Workshop on Optical Burst Switching, California, United States of America, October, 2004.
- Brelaz, D. 1979. New methods to color the vertices of a graph. Communications of the Association for Computing Machinery (ACM). 22(4), 251-256.
- Chen, Y. Qiao, C. and Yu, X. 2004. Optical burst switching: a new area in optical networking research. Institute of Electrical and Electronics Engineers (IEEE) Network. 18(3), 16-23.
- Choi, J.Y., Choi, J. and Kang, M. 2005. Dimension burst assembly process in optical burst switching. Institute of Electronics, Information and Communication Engineers (IEICE) Transactions on Communications. E88-B(10), 3855-3863.
- Coutelen, T., Elbiaze, H. and Jaumard, B. 2005. Performance comparison of OCS and OBS switching paradigms. Proceedings of 7th International Conference in Transparent Optical Networks, Delhi, India, July 3-7, 2005, 212-215.
- DAWN Networking Research Labs 2002. The Network Simulator-ns-2 at September 15<sup>th</sup> 2006. <http://www.isi.edu/nsnam/ns/>
- Dixit, S. 2003. IP over WDM: Building the next generation optical Internet (1). United States of America: John Wiley & Sons Publication.
- Du, P. and Sbe, S. 2007. Traffic analysis and traffic-smooth burst assembly methods for the optical burst switching network. Institute of Electronics, Information and

- Communication Engineers (IEICE) Transactions on Communications. E90-B(7), 1620-1630.
- Ezouganeli, E., Andreassen, R.Ø., Feng, B., Solem, A., Stol, N., KjØnsberg, H., SudbØ, A., Helvi, B.E.K. and Haugen, R.B. 2005. Why bother with optical packets? An evaluation of the viability of optical packet/burst switching. *Elektronikk, Optical Communications*. 2, 126-147.
- Gauger, C.M., KOhn, M. and Scharf, J. 2004. Comparison of contention resolution strategies in OBS network scenarios. *Proceedings of 6th International Conference on Transparent Optical Networks*, Wroclaw, Poland, July 4-8, 2004, 18-21.
- James, J.H., Chen, B. and Garrison, L. 2004. Implementation VoIP a voice transmission performance progress report. *Institute of Electrical and Electronics Engineers (IEEE) Communications Magazine*. 42(7), 36-41.
- Takehashi, S., Hasegawa, H. and Sato, K. 2008. Optical cross-connect switch architectures for hierarchical optical path networks. *Institute of Electronics, Information and Communication Engineers (IEICE) Transactions on Communications*, E91-B(10), 3174-3184.
- Kamiyama, N. 2004. Comparison of all-optical architectures for backbone networks. *Institute of Electronics, Information and Communication Engineers (IEICE) Transactions on Communications*. E87-B(6), 2877-2885.
- Parthiban, R., Leckie, C., Zalesky, A., Zukerman, M. and Tucker, R.S. 2009. Cost comparison of optical burst switched and automatically switched optical networks. *Institute of Electrical and Electronics Engineers/Optical Society of America (IEEE/OSA) Journal of Lightwave Technology*. 27(13), 2315-2329.
- Qin, X. and Yang, Y. 2002. Nonblocking WDM switching networks with full and limited wavelength conversion. *Institute of Electrical and Electronics Engineers (IEEE) Transactions on Communications*, 50(12), 2032-2041.
- Ramaswami, R. and Sivarajan, K.N. 1996. Design of logical topology for wavelength-routed optical networks. *Institute of Electrical and Electronics Engineers (IEEE) Journal on Selected Areas in Communications*. 14(5), 840-851.
- Schupke, D.A. and Sellier, D. 2001. Lightpath configuration of transparent and static WDM networks for IP traffic. *Institute of Electrical and Electronics Engineers (IEEE) International Conference on Communications*, Helsinki, Finland, June 11-14, 2001, 494-498.
- Sengupta, S., Kumar V. and Saha, D. 2003. Switched optical backbone for cost-effective scalable core IP networks. *Institute of Electrical and Electronics Engineers (IEEE) Communications Magazine*. 41(6), 60-70.
- Simons, J.M. 2006. Network in realistic all-optical backbone networks. *Institute of Electrical and Electronics Engineers (IEEE) Communications Magazine*. 44(11), 88-95.
- Tachibana, T. and Kasahara, S. 2006. Burst-cluster transmission: service differentiation mechanism for immediate reservation in optical burst switching networks. *Institute of Electrical and Electronics Engineers (IEEE) Communications Magazine*. 44(5), 46-55.
- Xiong, Y., Vandenhoue, M. and Cankaya, H.C. 2000. Control architecture in optical burst-switched WDM networks. *Institute of Electrical and Electronics Engineers (IEEE) Journal on Selected Areas in Communications*. 18(10), 1838-1851.
- Xue, F. and Yoo, S.J.B. 2005. Performance comparison of optical burst and circuit switched networks. *Optical Fiber Communication/National Fiber Optic Engineers Conference (OFC/NFOEC)*, Technical Digest, California, United States of America, March 6-11, 2005, 1-3.
- Yang, Y. and Wang, J. 2005. Cost-effective designs of WDM optical interconnects. *Institute of Electrical and Electronics Engineers (IEEE) Transactions on Parallel and Distributed Systems*. 16(1), 51-66.
- Yoo, M. and Qiao, C. 1997. Just-Enough-Time (JET): A high speed protocol for bursty traffic in optical networks. *Proceedings of Institute of Electrical and Electronics Engineers/Lasers and Electro-Optics Society (IEEE/LEOS) in Technologies for a Global Information Infrastructure*, Montreal, Canada, August 11-15, 1997, 26-27.
- Yoo, M. and Qiao, C. 2000. QoS performance of optical burst switching in IP-Over-WDM networks. *Institute of Electrical and Electronics Engineers (IEEE) Journal on Selected Areas in Communications*. 18(10), 2062-2071.